

DETAIL : DRIVE SPECS

DETAIL E : HEAD COVER & SAFETY GUARDS

SECTION : TAIL DIMS & SPECS: TAIL DIMS & SPECS

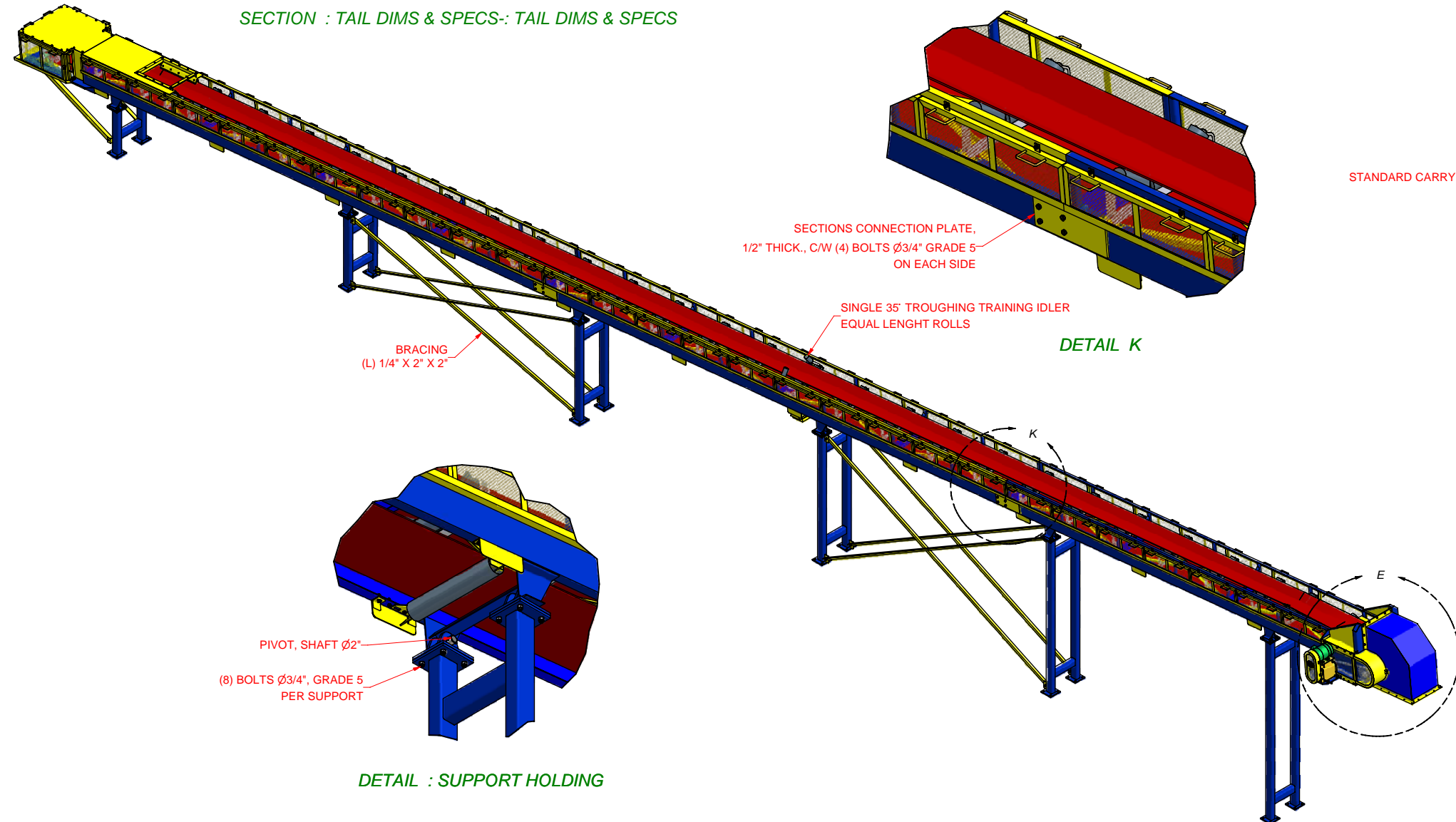

DETAIL K

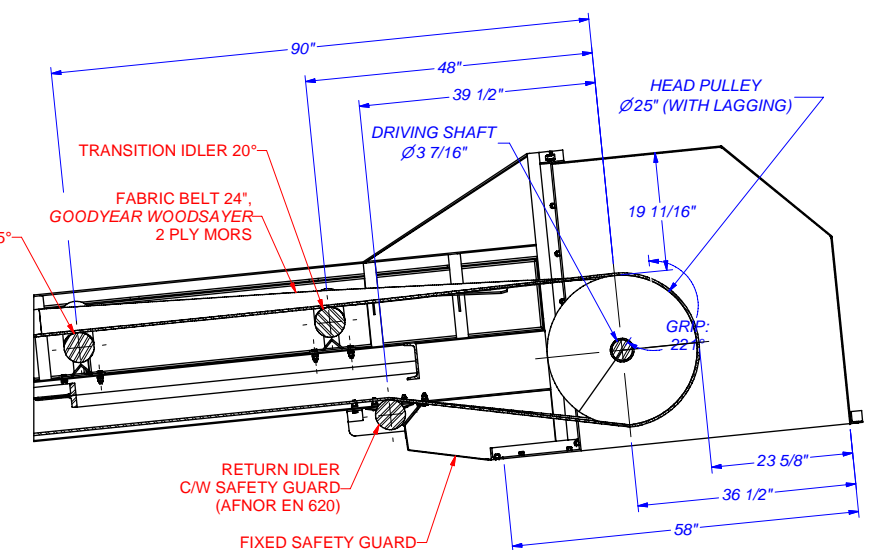

SECTION : HEAD DIMS & SPECS: HEAD DIMS & SPECS

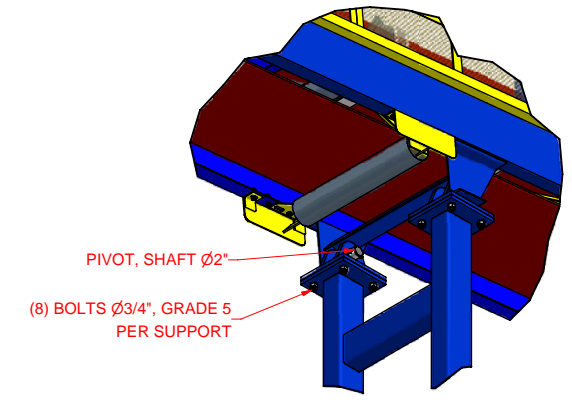

DETAIL : SUPPORT HOLDING

Tol.: ± 1/32" (Frac.)
 Tol.: .005" (Déc.)
 Sauf indication contraire

Les Aciers J.P. inc. Site web: www.acierjp.com	
Client: Louisiana-Pacific Corp Houlton	
Projet: 2346: Equip. #9020	
Pièce: Temp. Wet Fuel transfer Conv.	
Des par: D. Langevin	Feuille
Date: 2007-01-24	2 de 3
No dessin: 2346-9020-22.idw	Rev.: 1